

Bolt-On (Dodge 17" Part No. 44-1708)

Mounting style designed to bolt onto the OEM wheel by using "Two" original equipment (OEM) lug-nuts.

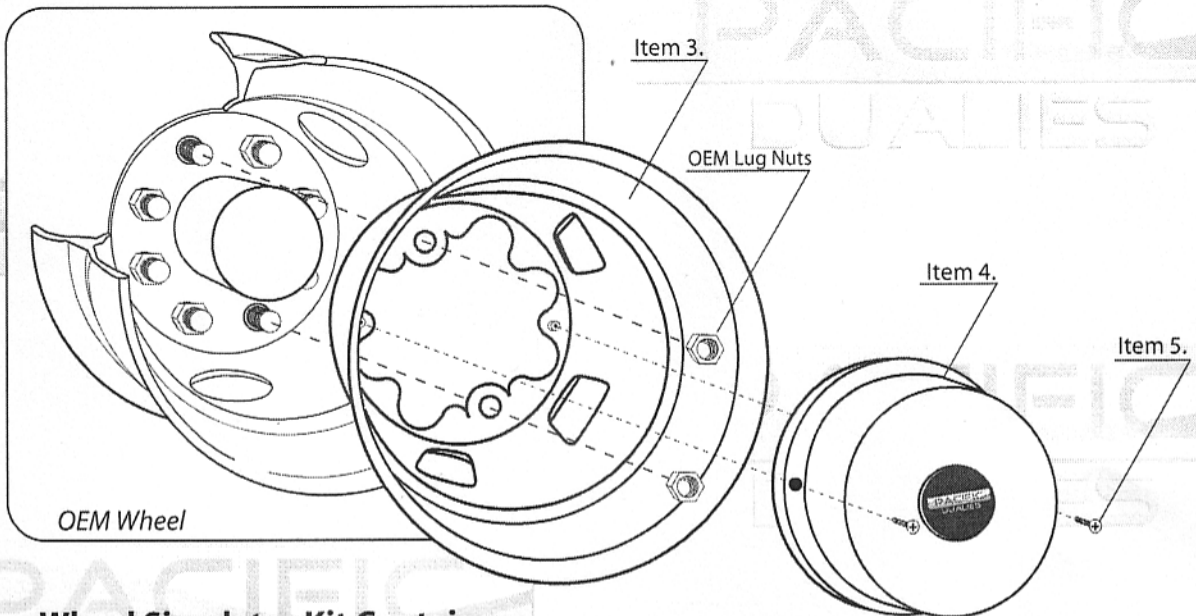

Wheel Simulator Kit Contains:

- Item 1. (2) Stainless Steel Front Simulators
- Item 2. (2) Stainless Steel Front Center Caps
- Item 3. (2) Stainless Steel Rear Simulators

- Item 4. (2) Stainless Steel Rear Center Caps
- Item 5. (8) Rear Center Cap Screws
- Item 6. (1) Center Cap Screw Tool

! WARNING

*Failure to follow all instructions could result in wheel loss, resulting in serious injury or death.
**Read all instructions before beginning installation & Follow all instructions in order presented.
***Be careful when handling products - some products have burrs & sharp edges from the manufacturing process; use of gloves and proper tools are highly-recommended.

Installation:

- Step 1. Begin by removing "Two" OEM lug nuts (Opposite each other) from the wheel.
- Step 2. Slide on either a front or rear wheel simulator onto the corresponding wheel, allowing the OEM studs to clear the blanked out area of the wheel simulator cover and allowing the studs go through the simulator stud holes.
- Step 3. Bolt the "Two" OEM lug nuts to the wheel, securing the wheel simulator cover firmly to the OEM Wheel.
- Step 4. Firmly Secure the corresponding front or rear center cap with the Center Cap screws supplied.
- Step 5. Repeat Steps 1-4 for each of the remaining wheels.